

GUIDE TO RESIDUAL CURRENT DEVICE (RCD) PROTECTION OF ELECTRIC VEHICLE (EV) CHARGING INSTALLATIONS

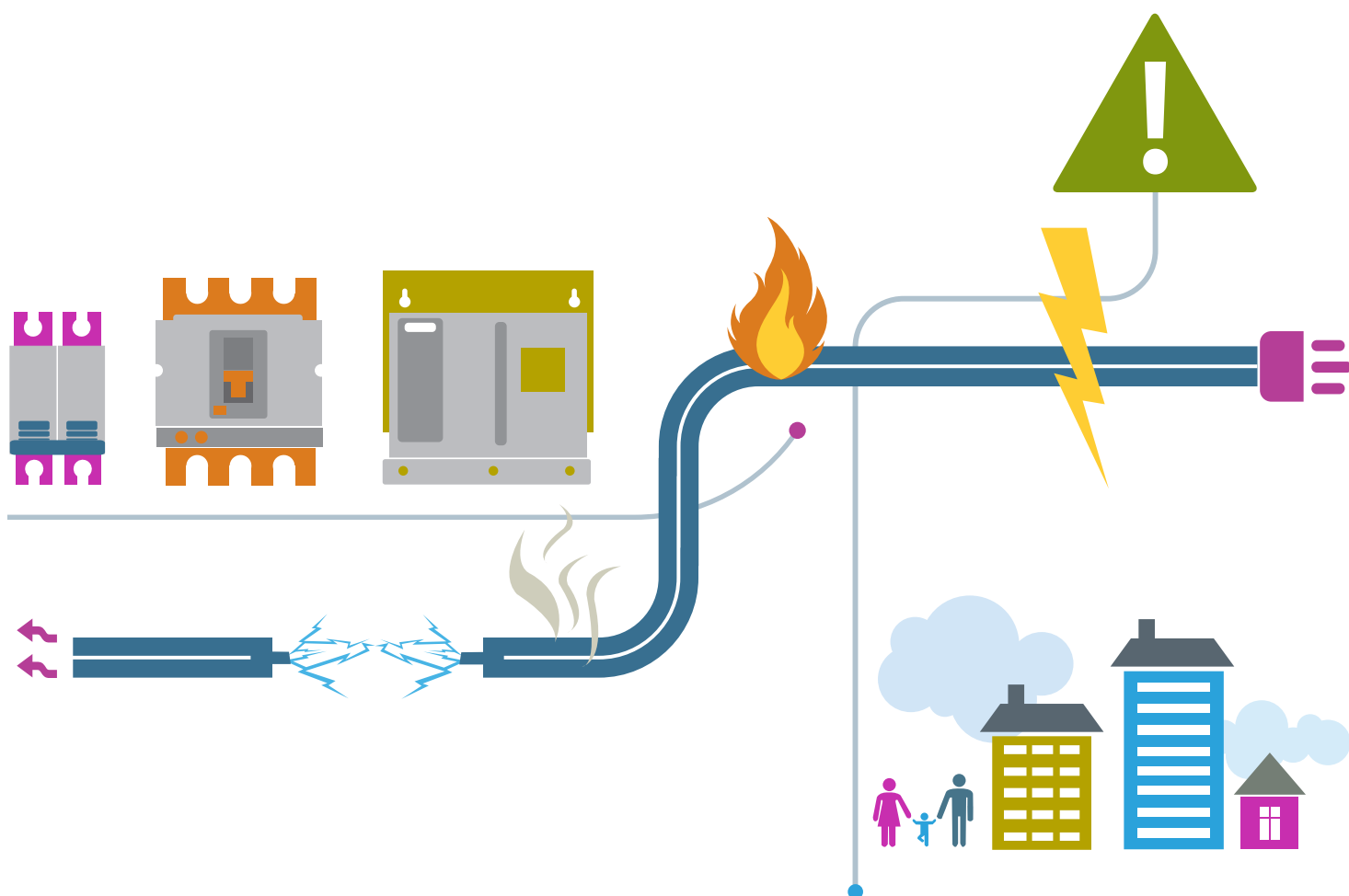

ABOUT BEAMA

BEAMA is the long established and respected trade association for the electrotechnical sector. The association has a strong track record in the development and implementation of standards to promote safety and product performance for the benefit of manufacturers and their customers.

This guide is intended as a practical guide for designers, specifiers and installers to enable them to specify Residual Current Device (RCD) Protection of Electric Vehicle (EV) charging installations.

This Guide has been produced by BEAMA's Building Electrical Systems Sector operating under the guidance and authority of BEAMA, supported by specialist central services for guidance on UK Internal Market, European Single Market, Quality Assurance, Legal and Health & Safety matters. BEAMA's Building Electrical Systems Sector comprises of major UK manufacturing companies.

Details of other BEAMA Guides can be found on the BEAMA website www.beama.org.uk

ACKNOWLEDGEMENTS

BEAMA would like to thank BSI, CENELEC and IEC for allowing references to their standards.

DISCLAIMER

This publication is subject to the copyright of BEAMA Ltd. While the information herein has been compiled in good faith, no warranty is given or should be implied for its use and BEAMA hereby disclaims any liability that may arise from its use to the fullest extent permitted under applicable law.

© BEAMA Ltd 2022

Copyright and all other intellectual property rights in this document are the property of BEAMA Ltd. Any party wishing to copy, reproduce or transmit this document or the information contained within it in any form, whether paper, electronic or otherwise should contact BEAMA Ltd to seek permission to do so.

COMPANIES INVOLVED IN THE PREPARATION OF THIS GUIDE



ABB Ltd

Tower Court; Courtaulds Way
Foleshill Enterprise Park
Coventry, West Midlands CV6 5NX
Tel: +44 (0) 2476 368 500
<https://new.abb.com/uk>



Contactum Limited

Victoria House, 2 Blackmoor Lane,
Croxley Green Business Park,
Watford, WD18 8GA

Tel: 0208 208 7400
enquiries@contactum.co.uk



Powering Business Worldwide

Eaton Electric Limited

252 Bath Road, Slough,
Berkshire SL1 4DX

Tel: +44 (0) 8700 545 333
Email: ukcommorders@eaton.com
www.eaton.com/uk



GreenBrook Electrical

62 West Road, Harlow,
Essex CM20 2BG
Tel + 44 (0) 1279 772772
www.greenbrook.co.uk



Hager Ltd

Hortonwood 50, Telford,
Shropshire TF1 7FT

Tel: +44 (0)1952 675 689
Email: Technical@hager.co.uk
www.hager.co.uk



Legrand Electric Ltd

Great King Street North,
Birmingham B19 2LF

Tel: +44 (0) 345 605 4333
Email: legrand.sales@legrand.co.uk
www.legrand.co.uk



Lewden

Unit 4, Bradbury Drive
Springwood Industrial Estate
Braintree, Essex, CM7 2SD
Tel: +44 01376 336200
sales@lewden.co.uk



Luceco plc

Luceco Distribution Centre,
Stafford Park 1, Telford,
Shropshire, TF3 3BD

Tel: +44 (0)1952 238 100
uk_sales@luceco.com



Schneider Electric Ltd

Stafford Park 5, Telford, Shropshire TF3 3BL

Tel: +44 (0) 1952 290029

Fax: +44 (0) 1952 292238

www.schneider-electric.co.uk



Electrium Sales Ltd (a Siemens Company)

Walkmill Lane, Bridgetown
Cannock, WS11 0XE

Tel: +44 (0) 1543 455000

Email: info@electrium.co.uk

www.electrium.co.uk



A theben Group Company

Timeguard Ltd

Victory Park, 400 Edgware Road
London NW2 6ND

Tel: +44 (0) 20 8450 0515

Fax: +44 (0) 20 8450 0635

Email: helpline@timeguard.com

www.timeguard.com



RESEARCH & DEVELOPMENT

Western Automation R&D

2 Atreus Place, Poolboy, Ballinalsoe,
Co. Galway, Ireland H53 TD 78

Tel: +353 (0) 90 9643359

Fax: +353 (0) 90 9643094

Email: info@westernautomation.com

www.westernautomation.com

CONTENTS

| | |
|--|----|
| Introduction | 5 |
| Abbreviations and Definitions | 5 |
| 1. RCD selection | 6 |
| 2. Effects of DC fault currents on RCDs | 7 |
| 3. RDC-DDs | 8 |
| 3.1. RDC-MDs | 8 |
| 3.2. RDC-PDs | 11 |
| 4. RDC-DD testing | 12 |
| 5. RCD protection for Electric Vehicle wireless power transfer | 13 |

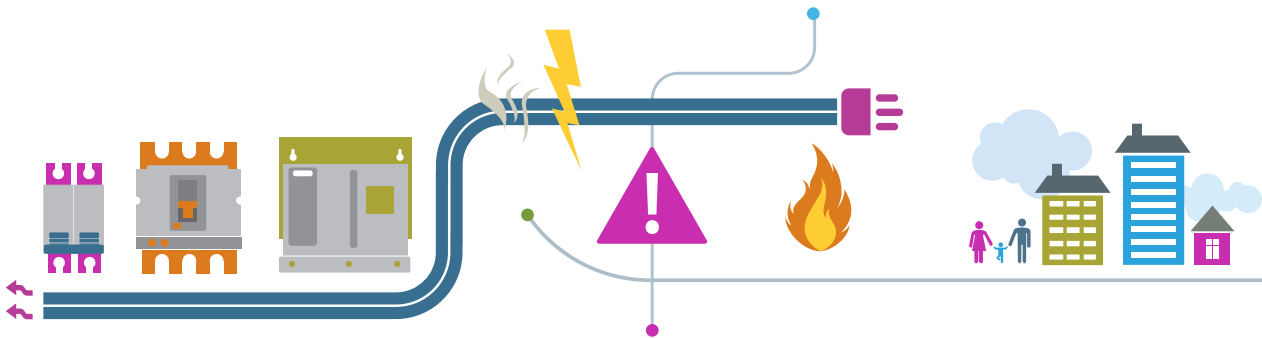

INTRODUCTION

With the increased uptake of electric vehicles, installers of EV charging circuits are faced with new requirements/products for the protection of such circuits. This guide covers the various options/products for RCD protection of EV charging circuits.

The general requirements of BS 7671, IET Wiring Regulations, apply however, the particular requirements detailed in Section 722 of BS 7671 supplement or modify the general requirements contained in other parts of BS 7671.

ABBREVIATIONS AND DEFINITIONS

Residual Direct Current Detecting Device (RDC-DD)

Detection device having at least the functionality of detection and evaluation of 6 mA DC residual currents and switching of the monitored circuit

Residual Direct Current Monitoring Device (RDC-MD)

Monitoring device capable of 6 mA DC residual current detection and mechanical switching

Residual Direct Current Protective Device (RDC-PD)

Protective device with integrated AC, pulsating DC and 6 mA DC detection, evaluation and mechanical switching

RDC-M-unit

Unit that includes detection and evaluation of residual currents and provides a mechanical operation to an RCD or circuit breaker to cause switching of the monitored circuit

RDC-M-module

Module to detect residual direct currents and to provide a signal to an electrically coupled switching device to cause switching of the monitored circuit

1. RCD SELECTION

BS 7671 Regulation 722.531.3.101 requires that, unless supplied by a circuit using electrical separation, individual protection by an RCD of at least Type A shall be provided. In addition, protection shall be provided against DC fault currents exceeding 6 mA. Protection of DC fault currents exceeding 6 mA may be provided by the EV charging equipment or a suitable device within the installation.

Where the EV charging equipment does not provide protection against DC fault current exceeding 6 mA, options to comply with the regulation are by means of installation of:

- Type B RCD; or
- Type A RCD, in conjunction with an RDC-DD; or
- Type F RCD, in conjunction with an RDC-DD.

RCDs shall conform to one of the following standards:

- BS EN (IEC) 61008-1
- BS EN (IEC) 61009-1
- BS EN (IEC) 60947-2
- BS EN (IEC) 62423

RDC-DDs shall conform to BS IEC 62955. An EN adoption of the IEC 62955 did not exist at the time of publication of this guide.

An RCD Type A or Type F in conjunction with an RDC-DD can be arranged with the RDC-DD inside the EV charging equipment and the Type A or Type F RCD upstream in either the charging equipment or the installation e.g., at the distribution board / consumer unit. The location of the RCD may be dependent on the method of installation and / or type of EV charger supply cable.

2. EFFECTS OF DC FAULT CURRENTS ON RCDS

DC fault currents may affect the performance of some types of RCD:

- DC fault currents of any magnitude applied to a Type AC RCD may impair operation of the RCD and in a worst-case situation render the RCD inoperable.
- DC fault currents exceeding 6 mA applied to a Type A may impair operation of the RCD and in a worst-case situation render the RCD inoperable.
- DC fault currents exceeding 10 mA applied to a Type F RCD may impair operation of the RCD and in a worst-case situation render the RCD inoperable.

Care must be taken where upstream 'in-series' RCDs are installed within the installation.

A Type AC RCD should not be fitted upstream of a Type A, F or B RCD as the load characteristics for which the Type A, F or B RCD has been selected could impair operation of the Type AC RCD or in a worst-case situation render the RCD inoperable; commonly termed as 'RCD blinding'.

A Type A or Type F RCD should not be fitted upstream of a Type B RCD as the load characteristics for which the Type B RCD has been selected could impair operation of the Type A or Type F RCD or in a worst-case situation render the RCD inoperable; commonly termed as 'RCD blinding'.

NOTE: Type AC, A or F RCDs may, when specifically declared as a suitable arrangement by the RCD manufacturer, be fitted upstream of a Type B RCD.

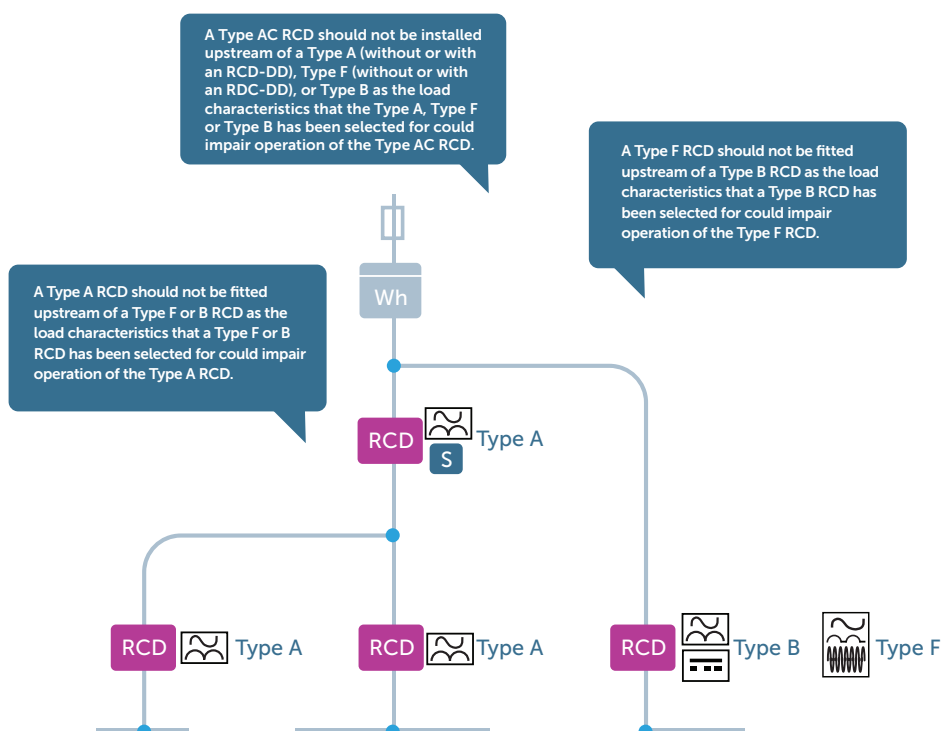

Figure 1: Example installation arrangement

3. RDC-DDs

RDC-DDs are for mode 3 charging of electric vehicles, they remove or initiate removal of the supply to the EV in cases where a smooth residual direct current equal to or above 6 mA is detected. As stated in Chapter 2 above, the applicable product standard for RDC-DDs is BS IEC 62955.

BS IEC 62955 classifies RDC-DDs as:

- RDC-MD
- RDC-PD

NOTE: Requirements for the selection and erection of RCDs in the case of supplies using DC vehicle connectors according to the BS EN (IEC) 62196 series are under consideration.

3.1 RDC-MDs

RDC-MDs are further classified according to their construction:

3.1.1 RDC-MD with mechanical switching in one unit

RDC-MD capable of 6 mA DC residual current detection, evaluation and mechanical switching in one unit.

For AC and pulsating DC protection, this RDC-MD is intended to be used with a Type A RCD according to BS EN (IEC) 61008 or BS EN (IEC) 61009 or a Type F RCD according to BS EN (IEC) 62423 with a residual operating current rating not exceeding 30 mA.

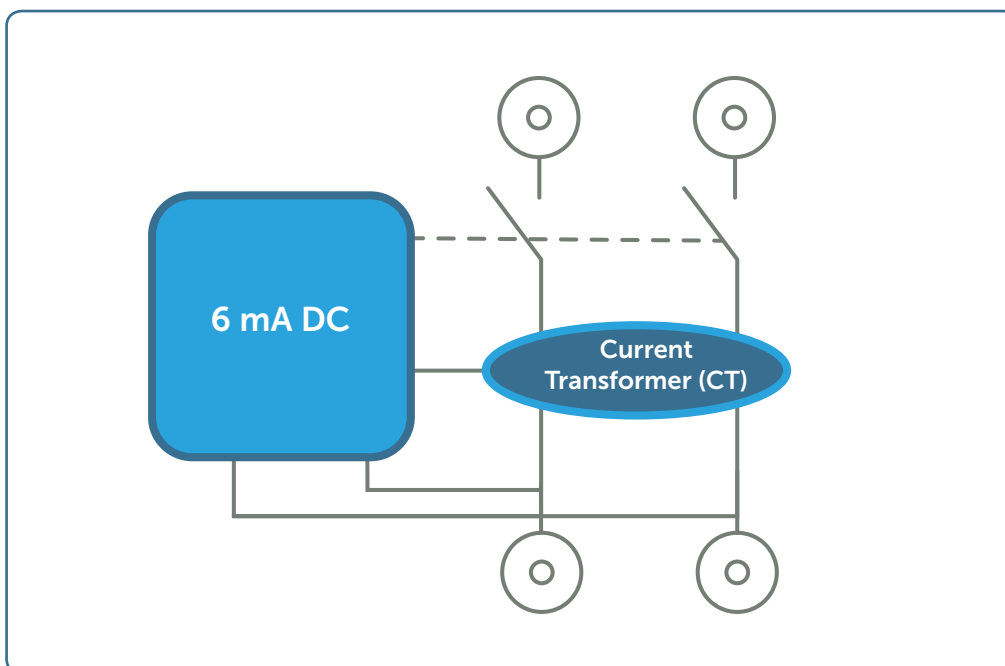

Figure 2: RDC-MD with mechanical switching in one unit

3.1.2 RDC-MD consisting of RDC-M-unit mechanically coupled to a separate protective device

RDC-M-unit capable of 6 mA DC residual current detection and evaluation, mechanically coupled to a separate protective device:

- a) Residual Current Operated Circuit-Breaker without Integral Overcurrent protection (RCCB) Type A according to BS EN (IEC) 61008 or a Type F according to BS EN (IEC) 62423 with a residual operating current rating not exceeding 30 mA; or
- b) Residual Current Operated Circuit-Breaker with Integral Overcurrent protection (RCBO) Type A according to BS EN (IEC) 61009 or a Type F according to BS EN (IEC) 62423 with a residual operating current rating not exceeding 30 mA; or
- c) Miniature Circuit-Breaker (MCB) according to BS EN (IEC) 60898-1.

For AC and pulsating DC protection, this RDC-MD shall be used in series with a Type A RCD according to BS EN (IEC) 61008 or BS EN (IEC) 61009 or a Type F RCD according to BS EN (IEC) 62423 with a residual operating current rating not exceeding 30 mA.

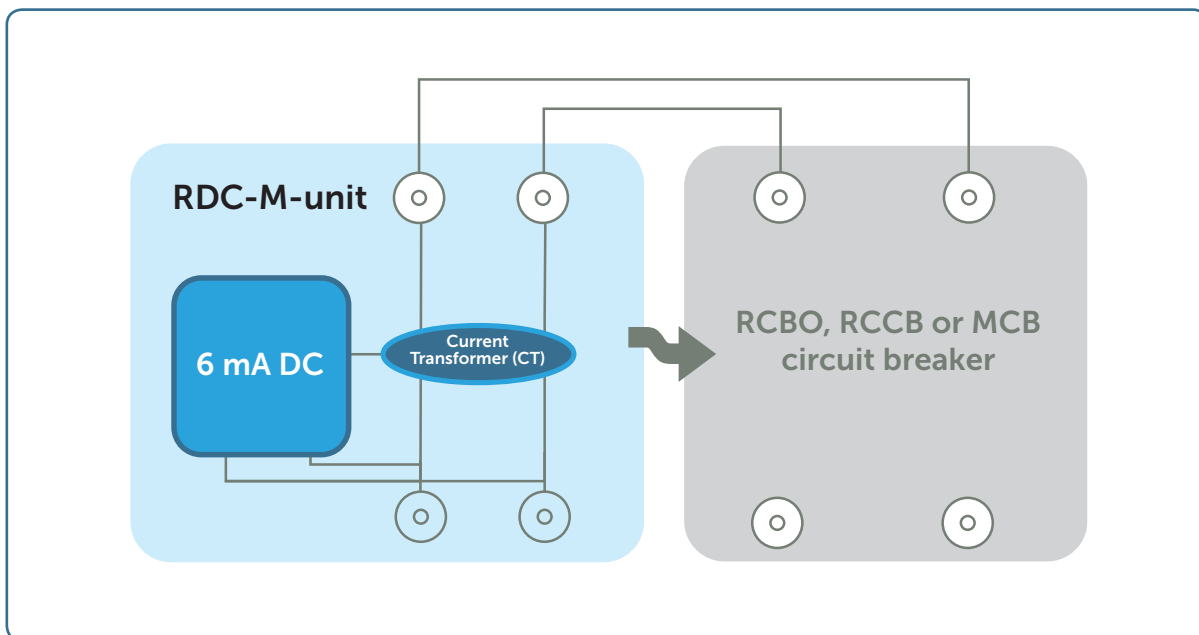

Figure 3: RDC-MD consisting of RDC-M-unit mechanically coupled to a separate protective device

3.1.3 RDC-MD consisting of RDC-M-module electrically coupled to a separate protective or switching device

RDC-M-module capable of 6 mA DC residual current detection and evaluation, electrically coupled to a separate protective or switching device. The switching device may be an RCD or a circuit breaker or a remotely operated switching device (e.g., contactor or relay) and may be actuated by using under-voltage or shunt trip operation:

- a) RCCB Type A according to BS EN (IEC) 61008 or a Type F according to BS EN (IEC) 62423 with a residual operating current rating not exceeding 30 mA; or
- b) RCBO Type A according to BS EN (IEC) 61009 or a Type F according to BS EN (IEC) 62423 with a residual operating current rating not exceeding 30 mA; or
- c) MCB according to BS EN (IEC) 60898-1; or
- d) A remotely operated switch e.g., contactor or relay.

For AC and pulsating DC protection, this RDC-MD shall be used in series with a Type A RCD according to BS EN (IEC) 61008 or BS EN (IEC) 61009 or a Type F RCD according to BS EN (IEC) 62423 with a residual operating current rating not exceeding 30 mA.

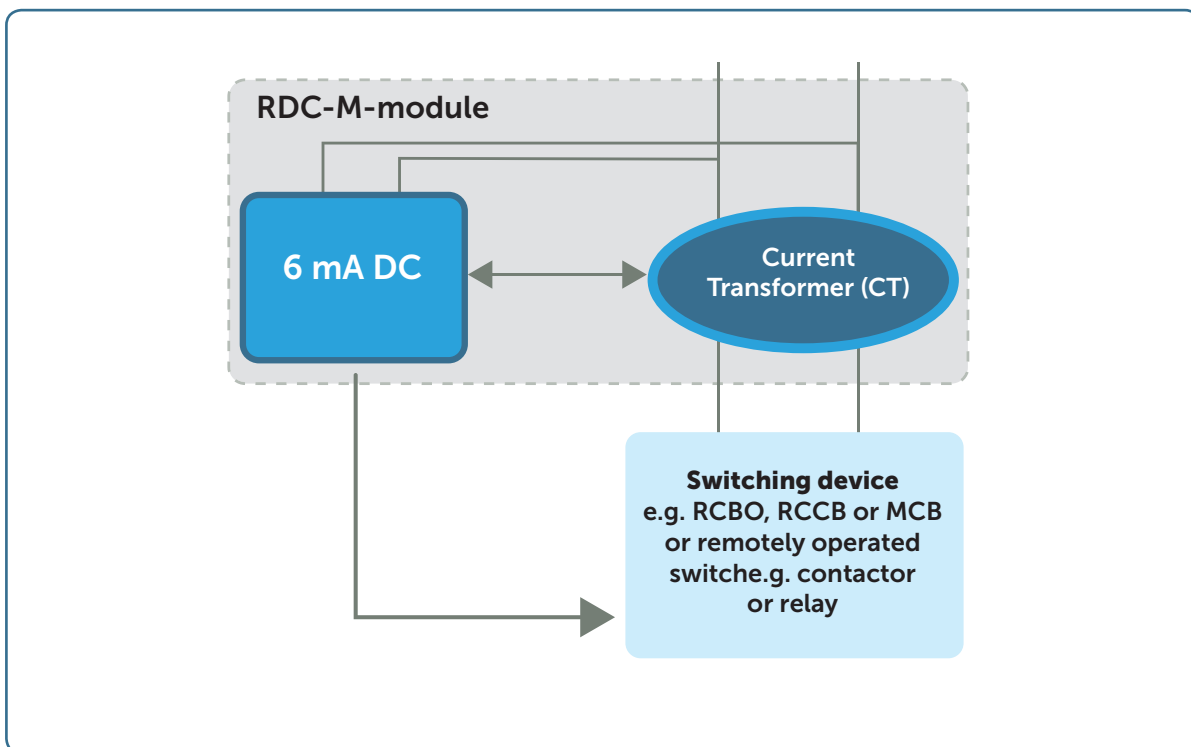

Figure 4: RDC-MD consisting of an RDC-M-module electrically coupled to a separate protective or switching device

3.2 RDC-PDs

RDC-PDs have integrated AC, pulsating DC and 6 mA DC detection, evaluation and mechanical switching in one unit. RDC-PDs are suitable for isolation.

RDC-PDs perform the function of > 6 mA DC fault current detection, plus 30 mA Type A RCD functionality.

In addition to the specific requirements of BS IEC 62955, the RDC-PD must conform to **all** the requirements and tests of the following product standards:

- RDC-PD integrated with an RCCB – BS EN (IEC) 61008-1
- RDC-PD integrated with an RCBO – BS EN (IEC) 61009-1

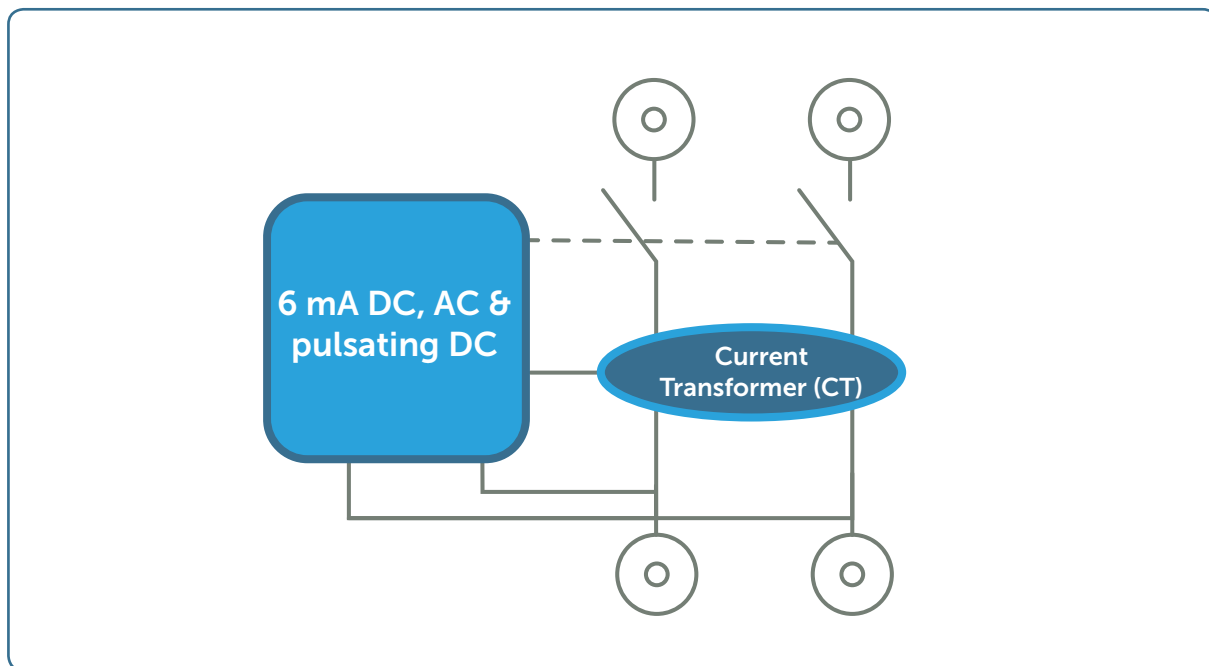

Figure 5: RDC-PD with integrated AC, pulsating DC and 6 mA DC detection, evaluation and mechanical switching in one unit

4. RDC-DD testing

RDC-DDs are provided with a manual or an automatically initiated test function, or both, that checks the residual DC detection circuit.

In the event of a manual test, the RDC-DD shall trip.

Where provided, the automatic test function shall be performed at every switch on and at intervals not exceeding at least once a day. During automatic testing, it is not required that the contacts open.

In the event that a malfunction is detected during automatic testing, the RDC-DD shall cause disconnection of the supply to the EV.

Further installation testing of RDC-DDs is not required.

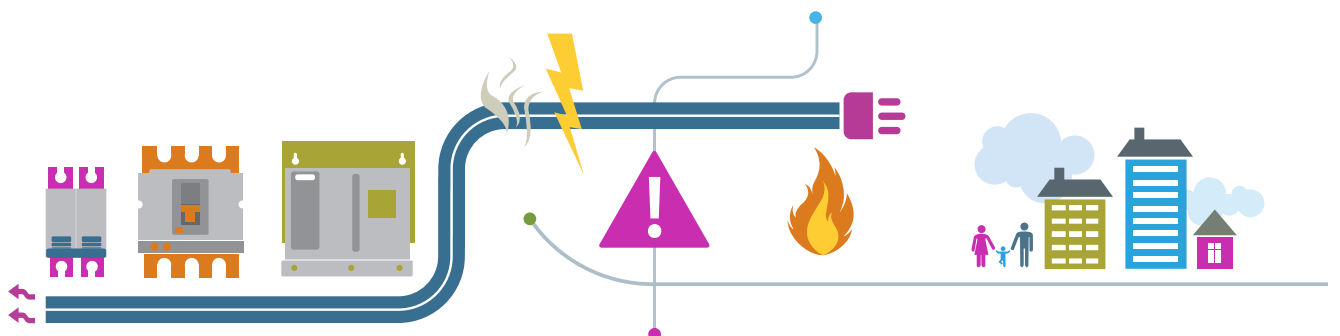

5. RCD protection for Electric Vehicle wireless power transfer

RCD protection for EV wireless power transfer is covered by BS EN IEC 61980-1, where the following requirements are specified:

A permanently connected supply device shall provide one or more of the following measures for each connecting point:

- An RCD Type B, and the installation instructions shall indicate that the supply network shall provide either no RCD or an RCD Type B; or
- An RCD Type A and a measure that limits the resulting DC component of the current in the protective earthing conductor to 6 mA in normal operation and under first fault conditions, and the installation instructions shall indicate that no RCD is required in the supply network; or
- for supply equipment with a single connecting point, a measure that limits the resulting DC component of the current in the protective earthing conductor to 6 mA in normal operation and under first fault conditions, and the installation instructions shall indicate that the supply network shall provide an RCD Type A; or
- None, if the supply device provides a single connecting point and the installation instructions indicate that the supply network shall provide an RCD Type B or an RCD Type A and a measure that limits the resulting DC component of the current in the protective earthing conductor to 6 mA in normal operation and under first fault conditions.

A plug and cable connected supply device shall include an RCD Type A and a measure that limits the resulting DC component of the current in the protective earthing conductor to 6 mA in normal operation and under first fault conditions.

The measure that limits the resulting DC component of the current in the protective earthing conductor to 6 mA includes, but is not limited to, the appropriate equipment that disconnects the supply in case of DC fault current above 6 mA.

RCDs shall comply with BS EN (IEC) 60947-2, BS EN (IEC) 61008-1, BS EN (IEC) 61009-1 or BS EN (IEC) 62423.

RCDs shall be used in conjunction with an over-current protection device.

RCDs and other devices providing personnel protection against electric shock shall not automatically reset.



Rotherwick House
3 Thomas More Street
London E1W 1YZ

www.beama.org.uk